

# 조합식계량기

MULTIHEAD WEIGHER

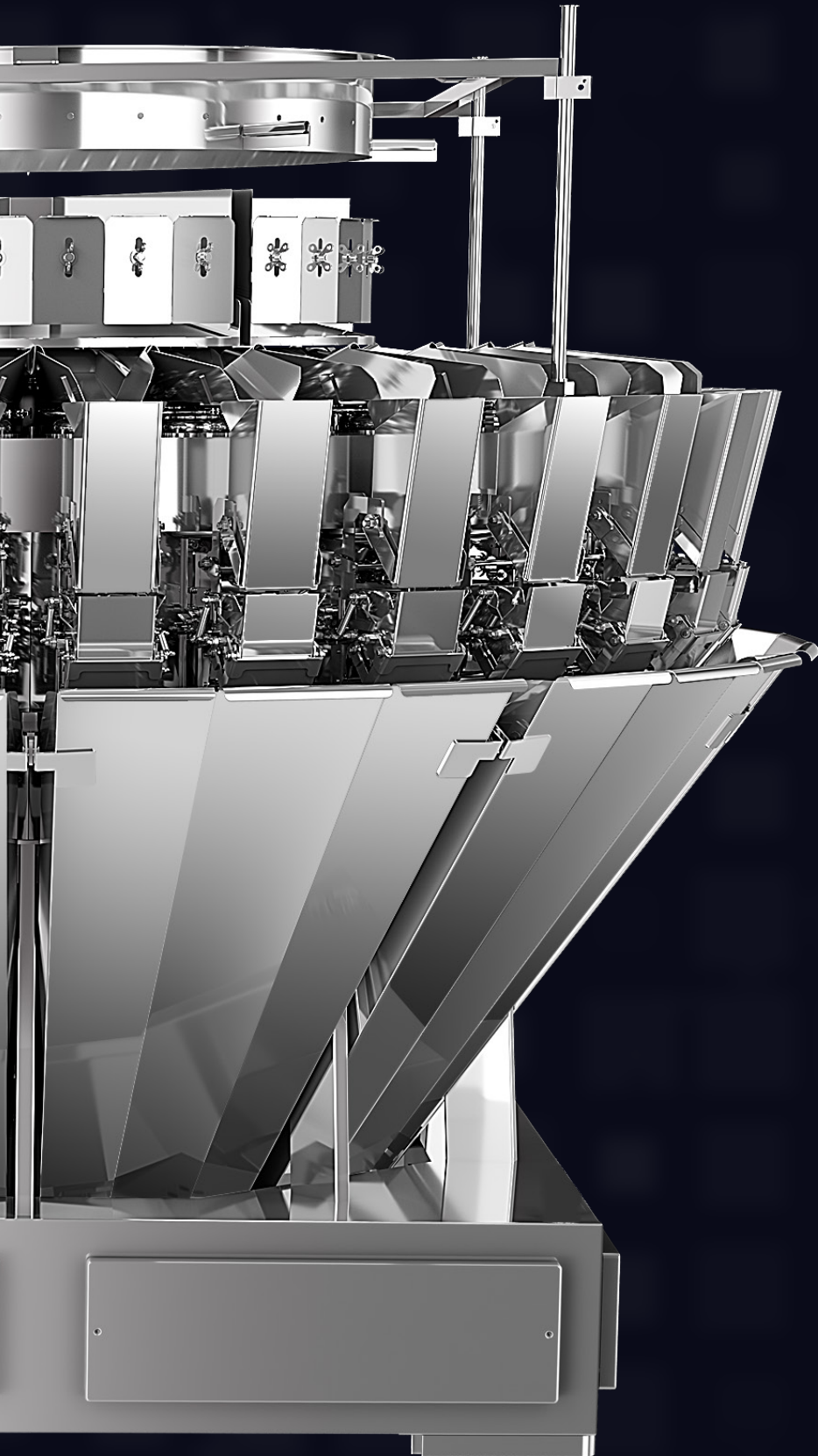

**WE TOUCH THE CORE**







주식회사 이지시스템은 자동계량포장시스템을 전문으로 구축하는 회사입니다. 자동계량포장시스템에 대한 기획, 설계, 제작, 설치, 운영에 대한 토탈 엔지니어링업체로서 프로젝트를 통합관리하고 원가절감, 공기단축, 품질 및 생산성 향상을 고객에게 제공합니다. 공기단축, 품질 및 생산성 향상을 고객에게 제공합니다. 이를 위해 다양한 방면의 전문 기술인력을 보유하고 있으며 풍부한 경험과 지식을 바탕으로 고객만족과 성공적인 프로젝트의 완수를 위하여 항상 최선의 노력을 경주하고 있습니다.

EZ System regards itself as a best solution provier for weighing and packaging system in the food industry. Thanks to our accumulated experience and technologies, we have constructed state-of-the-art packaging facilities with the newest automation system. We formulate and propose systems that intergrate all of the relevant processes that include conveying, weighing, packaging, checking and cartoning. By providing such solutions, we help raise efficiency of packaging processes, leading to lower costs and shorter delivery times. We are fully equipped to offer comprehensive solutions, form machinery selection to product development, in response to the needs of customers. In EZ System, you can find a total packaging solution.

# 조합식계량기

## MULTIHEAD WEIGHER

조합식계량기는 식품 또는 비식품을 매우 빠르고 정밀하게 계량합니다.

Multihead weigher is delivers highly accurate, reliable and high speed weighing of food and non-food products.



### 공급 Supply

바이브로피더 & 호퍼  
버킷엘리베이터  
Z 컨베이어  
Vibrofeeder & Hopper  
Bucket Elevator  
Z Conveyor

We select a supply that is optimized for the machine to be connected.

### 계량 Weighing

조합식계량기  
분체충진기  
액상충진기  
Multihead Weigher  
Auger Filler  
Liquid Filler

We select optimal weighing and filling machines according to the contents to be packaged.

### 포장 Packaging

로타리자동포장기  
수직형자동포장기  
Rotary Fill-Seal Machine  
Vertical Form-Fill-Seal Machine

We select the best possible models from a broad lineup of automatic packaging machines.

### 검사 Checking

금속검출기  
엑스레이검사기  
중량선별기  
Metal Detector  
X-ray Systems  
Check Weigher

We can integrate systems into the machines required for detecting inferior quality products, checking weight, checking for foreign substances, and other tasks.



## 특징 Features

- 고속 · 고정밀도의 계량이 가능합니다.
  - 청소가 용이하여 위생적입니다.
  - 작동방법이 간단합니다.
  - 조용한 작업환경을 제공합니다.
  - 데이터 관리 및 컴퓨터와 연결하여 네트워크를 구축할 수 있습니다.
  - 바이브레이터 방식의 제품 이송으로 제품의 손상이 거의 없습니다.
  - 다중배출 기능으로 가볍고 부피가 큰 제품의 계량도 가능합니다.
  - 순차배출 기능이 있어 부피가 큰 제품도 포장용기에 막힘 없이 계량이 가능합니다.
  - 어떠한 종류의 자동포장기와도 쉽게 연동이 가능하여 생산성을 극대화할 수 있습니다.
- Precise weighing accuracy and high speed.
  - Tool-less disassembly for quick wash-out.
  - Easy operation via color touch screen to make operation.
  - It provides a quiet working environment.
  - Synchronized with PC, can download and upload the parameter settings and statistics. also can monitor the running screen in the PC.
  - Almost no product damage due to the vibrator type product transfer.
  - Multi-dump function to achieve higher target weights.
  - Staggered discharge to avoid big pieces blocked.
  - Easily interfaced with any type of packaging machine for full automation.

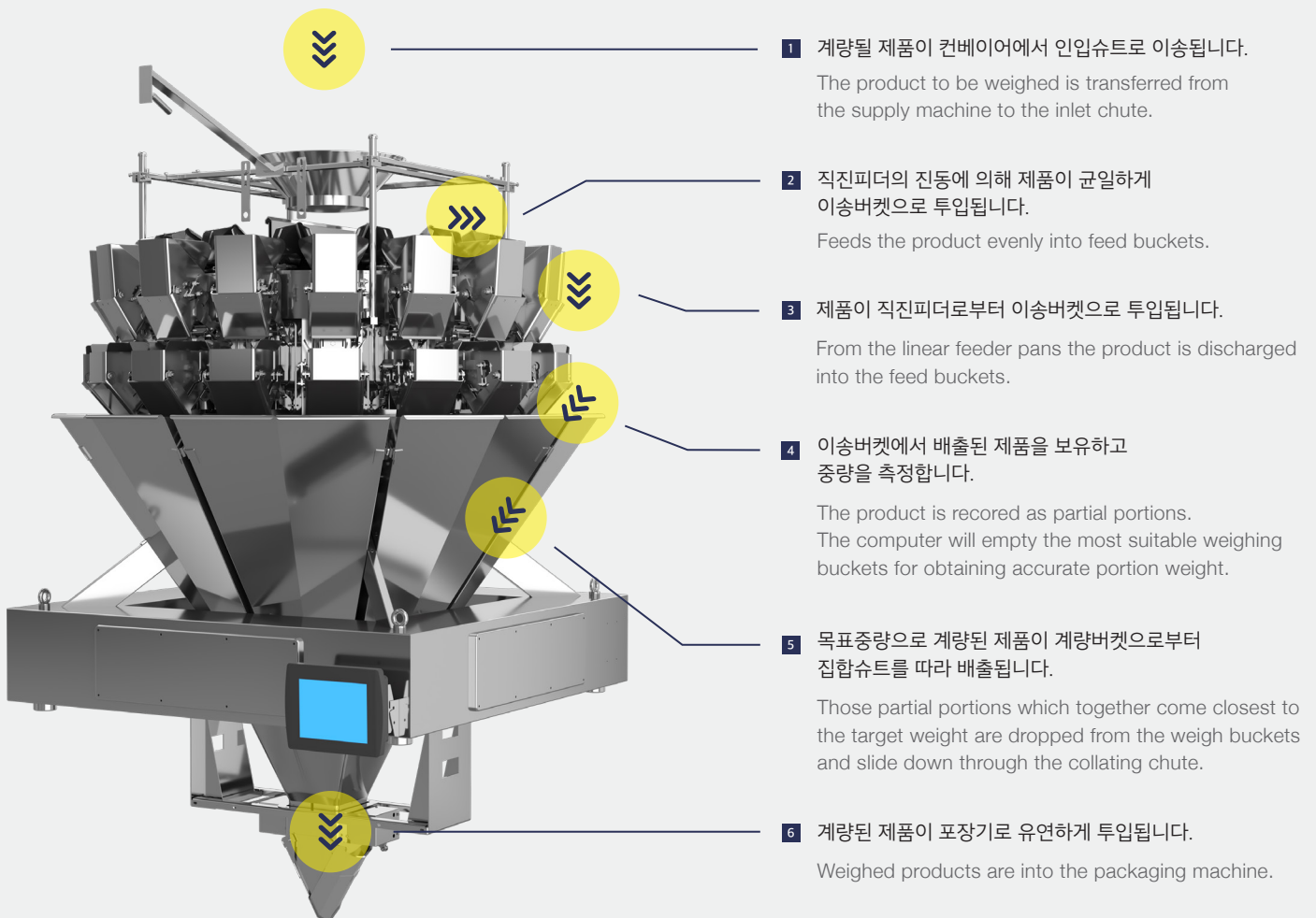

# 조합식계량기 | B Series

## BASIC MODEL WEIGHER



CS-1016-4GB



CS-1430-4GB



CS-2016-4GB

### 특징 Features

- 10/14/20 헤드로 구성된 Basic 계량기입니다.
- 보편적이고 일반적인 기종입니다.
- 싱글플랩/트윈플랩 방식으로 버킷이 개방되어 제품 계량을 용이하게 합니다.
- 견고한 디자인과 구조로 제작되었습니다.
- 스테인리스 스틸(SUS304) 구조로 제작되었습니다.
- The 10, 14, 20 head weigher weighs products efficiently and accurate at high speed and has been designed to handle almost any types of food products as well as non food applications.
- 4.0 generation modular control system.
- The single flap and twin flap opening system guarantees a complete discharge even of difficult and sticky product.
- Robust design and construction.
- Full stainless steel machine.

### 적용 Applications

냉동식품 / 가공식품 / 스낵류 / 캔디류 / 농산물 / 해산물 / 공업제품 등

Dry foods, Processed foods, Frozen foods, Fresh foods, Snack, Seeds, Candies, Nuts, Coffee, Beans, Pasta, Pet foods, Pharmaceuticals, Hardware



사양 TECHNICAL DETAILS			
품목 Item	4.0 Basic 10 Head Multihead Weigher	4.0 Basic 14 Head Multihead Weigher	4.0 Basic 20 Head Multihead Weigher
모델 Model	CS-1016-4GB	CS-1416-4GB	CS-2016-4GB
	CS-1030-4GB	CS-1430-4GB	CS-2030-4GB
계량헤드 수 No. of weighing head	10	14	20
최대속도 Max. speed(wpm)	70	110	120(60X2)
버킷용량 Bucket volume(L)	1.6/3		
제품 접촉부 Surface	Plain/Dimple		
계량범위 Weighing range(g)	10 ~ 3000		
계량정밀도 Accuracy(±g)	0.3 ~ 2		
모니터 Monitor	10.4 inch color touch screen		
소요 전력 Power consumption	220V 1PH 50/60Hz		
재질 Material in contact product	Stainless steel(SUS304)		
작동온도 Operation temperture(°C)	0 ~ 40		
방진방수등급 IP protection class	IP64		
선택사양 Option	제품에 특성에 따라 적용할 수 있는 다양한 선택사양이 있습니다. Various Options are available. Please contact EZ Systems.		

- 계량속도는 제품의 모양, 비중 및 목표중량에 따라 변동될 수 있습니다.
- 계량정밀도는 목표중량, 계량속도 및 주변환경에 따라 변동될 수 있습니다.
- 상기 사양은 기계 개선을 위해 예고 없이 변동될 수 있습니다.

- Depends on product shape, product density, target weight, etc.
- Depends on target weight, weighing speed and conditions.
- The technical modifications are reserved.



# 조합식계량기 | P Series

## PLUS MODEL WEIGHER



PC connection



Camera



USB data transfer



CS-1016-4GP



CS-1430-4GP



CS-2016-4GP

### 특징 Features

- 10/14/20 헤드로 구성된 Plus 모델의 계량기입니다.
- 빠르고 정밀함을 결합한 세계적 수준의 계량기입니다.
- 싱글플랩/트윈플랩 방식으로 버킷이 개방되어 제품 계량을 용이하게 합니다.
- 3D 메뉴 모니터로 더 쉽고 간단한 조작이 가능합니다.
- 스테인리스 스틸(SUS304) 구조로 제작되었습니다.
- 방수구조로 되어 있어 물청소가 가능하고 위생적입니다.
- 카메라가 부착되어 있어 계량동작 상황을 모니터 화면을 통해 볼 수 있습니다.
- 유무선 네트워크 기능을 탑재하여 컴퓨터를 통해 원격 제어가 가능합니다.
- USB를 통해 프로그램 저장 및 업그레이드가 가능합니다.
- The 10, 14, 20 head weigher weighs products efficiently and accurate at high speed and has been designed to handle almost any types of food products as well as non food applications.
- World-class multihead weigher combine fast and accurate weighing.
- The single flap and twin flap opening system guarantees a complete discharge even of difficult and sticky product.
- 3D menu monitor with smarter functions achieve easier and simpler operation.
- 4.0 generation modular control system.
- Full stainless steel machine.
- Software and mechanic improvements achieve top performance in the industry.



사양 TECHNICAL DETAILS			
품목 Item	4.0 Plus 10 Head Multihead Weigher	4.0 Plus 14 Head Multihead Weigher	4.0 Plus 20 Head Multihead Weigher
모델 Model	CS-1016-4GP	CS-1416-4GP	CS-2016-4GP
	CS-1030-4GP	CS-1430-4GP	CS-2030-4GP
계량헤드 수 No. of weighing head	10	14	20
최대속도 Max. speed(wpm)	80	130	140(70X2)
버킷용량 Bucket volume(L)	1.6/3		
제품 접촉부 Surface	Plain/Dimple		
계량범위 Weighing range(g)	10 ~ 3000		
계량정밀도 Accuracy(±g)	0.3 ~ 2		
모니터 Monitor	10.4 inch color touch screen		
소요 전력 Power consumption	220V 1PH 50/60Hz		
재질 Material in contact product	Stainless steel(SUS304)		
작동온도 Operation temperture(°C)	0 ~ 40		
방진방수등급 IP protection class	IP66		
선택사양 Option	제품에 특성에 따라 적용할 수 있는 다양한 선택사양이 있습니다. Various Options are available. Please contact EZ Systems.		

- 계량속도는 제품의 모양, 비중 및 목표중량에 따라 변동될 수 있습니다.
- 계량정밀도는 목표중량, 계량속도 및 주변환경에 따라 변동될 수 있습니다.
- 상기 사양은 기계 개선을 위해 예고 없이 변동될 수 있습니다.

- Depends on product shape, product density, target weight, etc.
- Depends on target weight, weighing speed and conditions.
- The technical modifications are reserved.

## 적용 Applications

냉동식품 / 가공식품 / 스낵류 / 캔디류 / 농산물 / 해산물 / 공업제품 등

Dry foods, Processed foods, Frozen foods, Fresh foods, Snack, Seeds, Candies, Nuts, Coffee, Beans, Pasta, Pet foods, Pharmaceuticals, Hardware



# 소형 계량기 | C Series

## COMPACT WEIGHER

---



CS-1008-4GB

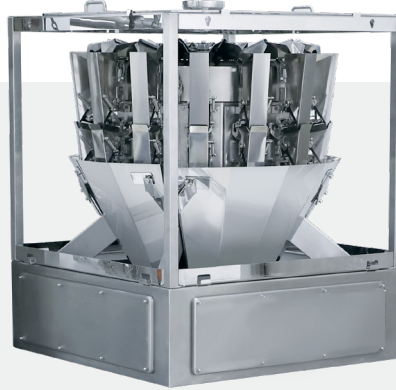

CS-1402-4GB



CS-1405-4GB

---

### 특징 Features

- 채소나 종자 등의 작고 가벼운 제품의 소량 중량을 빠르고 정밀하게 계량합니다.
- 본체가 콤팩트한 구조로 되어 있어 좁은 공간에서도 설치가 가능합니다.
- 제품의 낙하거리를 줄여 깨지기 쉬운 제품도 계량이 가능합니다.
- Small bucket multihead weigher.
- For small items such as vegetable seeds and fruit seeds.
- Compact design offers high accuracy on small target weight.
- The small size configuration reduces the height of the weigher which saves the space a lot.
- Soft handling design for fragile products by reducing the falling distance.



사양 TECHNICAL DETAILS			
품목 Item	10 Head Compact Multihead Weigher	14 Head Micro Multihead Weigher	14 Head Compact Multihead Weigher
모델 Model	CS-1008-4GB	CS-1402-4GB	CS-1405-4GB
계량헤드 수 No. of weighing head	10	14	14
최대속도 Max. speed(wpm)	70	120	110
버킷용량 Bucket volume	0.8	0.2	0.5
계량정밀도 Accuracy(±g)	0.1 ~ 1	0.03 ~ 0.05	0.1 ~ 1
계량범위 Weighing range(g)	2 ~ 300	0.5 ~ 50	2 ~ 300
제품 접촉부 Surface	Plain/Dimple		
모니터 Monitor	10.4 inch color touch screen		
소요 전력 Power consumption	220V 1PH 50/60Hz		
재질 Material in contact product	Stainless steel(SUS304)		
작동온도 Operation temperture(°C)	0 ~ 40°C		
방진방수등급 IP protection class	IP64		
선택사양 Option	제품에 특성에 따라 적용할 수 있는 다양한 선택사양이 있습니다. Various Options are available. Please contact EZ Systems.		

- 계량속도는 제품의 모양, 비중, 및 목표중량에 따라 변동될 수 있습니다.
- 계량정밀도는 목표중량, 계량속도 및 주변환경에 따라 변동될 수 있습니다.
- 상기 사양은 기계 개선을 위해 예고 없이 변동될 수 있습니다.

- Depends on product shape, product density, target weight, etc.
- Depends on target weight, weighing speed and conditions.
- The technical modifications are reserved.

## 적용 Applications

농산물종자 / 다류 / 건해산 / 알약 등

Seeds / Tea leaves / Dried herbs / Dried seafoods / Capsules



# 대용량 계량기 | BB Series

## LARGE VOLUME WEIGHER

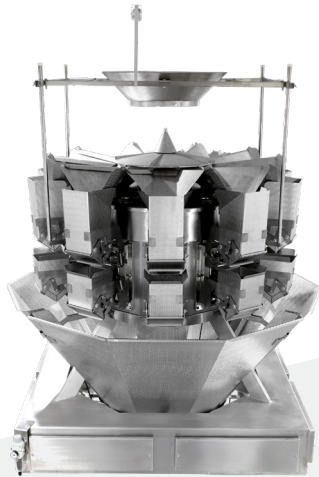

CS-1055BB-4GP

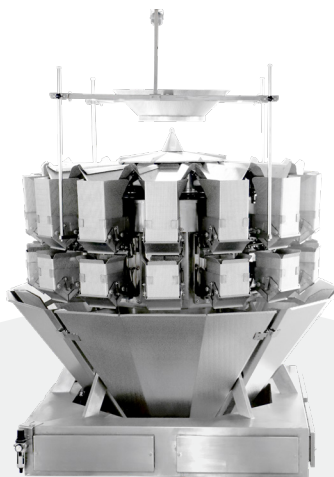

CS-1455BB-4GP



CS-1655BB-4GP



Stainless steel housing



Waterproof protection

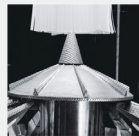

Adjustable rotating top cone



PC connection



Camera



USB data transfer

### 특징 Features

- 셸러드와 같이 부피가 큰 제품 계량에 적합한 계량기입니다.
- 방수구조로 되어 있어 물청소가 가능하고 위생적입니다.
- 방사판이 회전형으로 되어 있어 제품을 균일하게 분산시킵니다.
- 모든 제품 접촉부가 스테인리스 스틸(SUS304)로 제작되어 위생적이며 내구성이 뛰어납니다.
- 버킷용량이 5.5L, 7.5L 2종류(택일)가 있어 다양한 제품을 적용시킬 수 있습니다.
- 카메라(선택사양)가 부착되어 있어 계량동작 상황을 모니터 화면을 통해 볼 수 있습니다.
- 유무선 네트워크 기능을 탑재하여 컴퓨터를 통해 원격 제어가 가능합니다.(모델별 사양 확인)
- USB를 통해 프로그램 저장 및 업그레이드가 가능합니다.
- B series weigher is suitable for weighing bulky products.
- Water cleaning is possible.
- The top cone rotates to evenly distribute the product.
- Full stainless steel machine.
- There are two types of bucket capacity (5.5L / 7.5L), so can apply various products.
- Software and mechanic improvements achieve top performance in the industry.

사양 TECHNICAL DETAILS			
품목 Item	Large Volume Hopper 10 Head Multihead Weigher	Large Volume Hopper 14 Head Multihead Weigher	Large Volume Hopper 16 Head Multihead Weigher
모델 Model	CS-1055BB-4GB / CS-1055BB-4GP	CS-1455BB-4GB / CS-1455BB-4GP	CS-1655BB-4GB / CS-1655BB-4GP
	CS-1075BB-4GB / CS-1075BB-4GP	CS-1475BB-4GB / CS-1475BB-4GP	CS-1675BB-4GB / CS-1675BB-4GP
계량헤드 수 No. of weighing head	10	14	16
최대속도 Max. speed(wpm)	50/70	70/80	100
버킷용량 Bucket volume(L)	5.5 / 7.5		
제품 접촉부 Surface	Plain/Dimple		
계량범위 Weighing range(g)	25 ~ 5000		
계량정밀도 Accuracy(±g)	1 ~ 3		
에어 Air(bar)	5 ~ 6		
소요 전력 Power consumption	220V 1PH 50/60Hz		
재질 Material in contact product	Stainless steel(SUS304)		
작동온도 Operation temperature(°C)	0 ~ 40		
방진방수등급 IP protection class	IP64 / IP66		
모니터 Monitor	10.4 inch color touch screen		
선택사양 Option	제품에 특성에 따라 적용할 수 있는 다양한 선택사양이 있습니다. Various Options are available. Please contact EZ Systems.		

- 계량속도는 제품의 모양, 비중 및 목표중량에 따라 변동될 수 있습니다.
- 계량정밀도는 목표중량, 계량속도 및 주변환경에 따라 변동될 수 있습니다.
- 상기 사양은 기계 개선을 위해 예고 없이 변동될 수 있습니다.

- Depends on product shape, product density, target weight, etc.
- Depends on target weight, weighing speed and conditions.
- The technical modifications are reserved.

## 적용 Applications









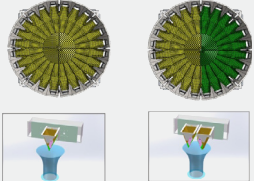
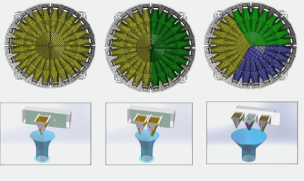
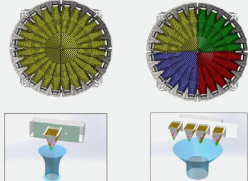
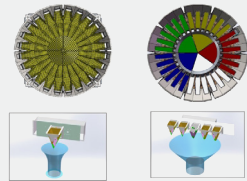
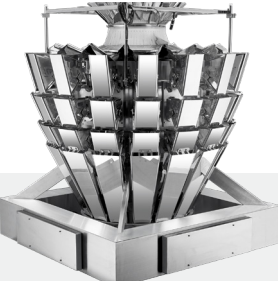

냉동식품 / 가공식품 / 얼음 / 샐러드 / 야채류 등

Frozen foods / Processed foods / Bread / Crushed ice / Salad / Vegetables

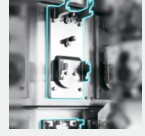

# 메모리버킷계량기 | MB Series

## MEMORY BUCKET WEIGHER

 <p>1종 계량 1 Product</p> <p>2종 믹스 계량 2 Mix</p>	 <p>1종 계량 1 Product</p> <p>2종 믹스 계량 2 Mix</p> <p>3종 믹스 계량 3 Mix</p>	 <p>1종 계량 1 Product</p> <p>4종 믹스 계량 4 Mix</p>	 <p>1종 계량 1 Product</p> <p>5종 믹스 계량 5 Mix</p>			
 <p><b>CS-1620M-4GP</b></p>	 <p><b>CS-1808M-4GP</b></p>	 <p><b>CS-2408M-4GP</b></p>	 <p><b>CS-3008M-4GP</b></p>			
 <p>Stainless steel housing</p>	 <p>Actuator unit</p>	 <p>Memory bucket</p>	 <p>Mixing</p>	 <p>PC connection</p>	 <p>Camera</p>	 <p>USB data transfer</p>

### 특징 Features

- 메모리버킷이 장착되어 있어 분당 최대 180 ~ 300회의 계량이 가능합니다.
- 3단 구성의 버킷 구조입니다 : 이송버킷, 계량버킷, 메모리버킷
- 다양한 배출포인트(1 ~ 5) 구성이 가능하여 단일 제품을 초고속으로 계량하거나 1 ~ 5종류의 제품을 한 대의 계량기에서 계량이 가능합니다.
- 모든 제품 접촉부가 스테인리스 스틸(SUS304)로 제작되어 위생적이며 내구성이 뛰어납니다.
- 방수구조로 되어 있어 물청소가 가능하고 위생적입니다.
- 카메라(선택사양)가 부착되어 있어 계량동작 상황을 모니터 화면을 통해 볼 수 있습니다.
- 유무선 네트워크 기능을 탑재하여 컴퓨터를 통해 원격 제어가 가능합니다.
- USB를 통해 프로그램 저장 및 업그레이드가 가능합니다.
- MB Series with a memory bucket, it is possible to weigh up to 150~300 times per minute.
- Various discharge points(1 to 5) can be configured to measure one product at high speed or to weigh 1 to 5 types of products with a weigher.
- Full stainless steel machine.
- Camera(optional) is attached, the weighing operation status can be viewed on the monitor.
- Software and mechanic improvements achieve top performance in the industry.



사양 TECHNICAL DETAILS

품목 Item	16 Head Mix Weigher With Memory Bucket	18 Head Mix Weigher With Memory Bucket	24 Head Mix Weigher With Memory Bucket	30 Head Mix Weigher With Memory Bucket
모델 Model	CS-1620M-4GP	CS-1808M-4GP	CS-2408M-4GP	CS-3008M-4GP
계량헤드 수 No. of weighing head	16	18	24	30
최대속도 Max. speed(wpm)	150, 2x75	200, 2x90, 3x65	240, 4x60	300, 5x60
배출포인트 Discharge point	1, 2	1, 2, 3	1, 4	1, 5
버킷용량 Bucket volume(L)	2	0.8	0.8	0.8
계량범위 Weighing range(g)	15 ~ 1000	15 ~ 500	15 ~ 500	15 ~ 500
계량정밀도 Accuracy(±g)	1 ~ 2	0.5 ~ 1	0.5 ~ 1	0.5 ~ 1
제품 접촉부 Surface	Plain/Dimple			
모니터 Monitor	10.4 inch color touch screen			
소요 전력 Power consumption	220V 1PH 50/60Hz			
재질 Material in contact product	Stainless steel(SUS304)			
작동온도 Operation temperture(°C)	0 ~ 40			
방진방수등급 IP protection class	IP66			
선택사양 Option	제품에 특성에 따라 적용할 수 있는 다양한 선택사양이 있습니다. Various Options are available. Please contact EZ Systems.			

- 계량속도는 제품의 모양, 비중 및 목표중량에 따라 변동될 수 있습니다.
- 계량정밀도는 목표중량, 계량속도 및 주변환경에 따라 변동될 수 있습니다.
- 상기 사양은 기계 개선을 위해 예고 없이 변동될 수 있습니다.

- Depends on product shape, product density, target weight, etc.
- Depends on target weight, weighing speed and conditions.
- The technical modifications are reserved.

메모리버킷 계량 원리 Memory bucket weighing principle

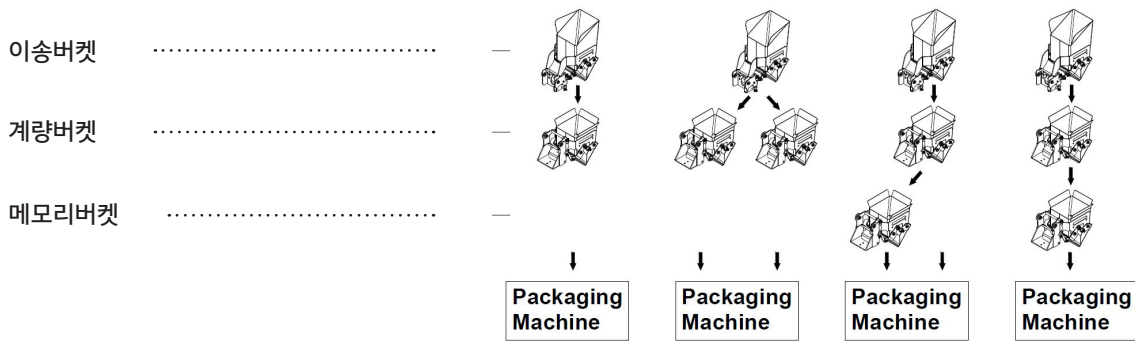

적용 Applications

혼합제품 / 견과 / 스낵 / 캔디 / 냉동식품 / 가공식품 / 농산물 등

Mix products / Nuts / Snack / Candies / Dry foods



# 점착물 계량기 | LI Series

## HIGH STICKY AND FRESH FOODS WEIGHER



CS-0615M-4GP



CS-0815M-4GP

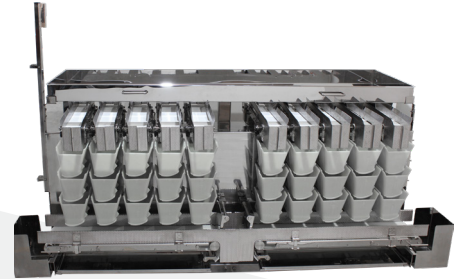

CS-1015M-4GP



Belt feeder



Screw feeder



Sliding bucket



PC connection



Camera



USB data transfer

### 특징 Features

- 원형식 계량기에서 계량이 어려운 점착물 제품이나 신선식품 계량에 적합한 계량기입니다.
- 슬라이딩 방식의 버킷이 부착되어 있어 버킷 내부에 잔여물이 거의 남지 않아 계량정밀도가 향상됩니다.
- 플라스틱 버킷 내면은 줄무늬로 되어 있어 있습니다.
- 물청소가 가능한 위생적인 구조로 되어 있습니다.
- 모든 제품 접촉부는 공구 없이 탈착이 가능합니다.
- It is suitable for weighing sticky and fresh products.
- Buckets with scraper doors to force sticky products down.
- 3-level buckets including memory buckets to increase speed and accuracy.
- Water cleaning is possible.
- All product contacts are removable without tools.

사양 TECHNICAL DETAILS			
품목 Item	High Sticky 6 head Multihead Weigher	High Sticky 8 head Multihead Weigher	High Sticky 10 head Multihead Weigher
모델 Model	CS-0615M-4GP	CS-0815M-4GP	CS-1015M-4GP
계량헤드 수 No. of weighing head	6	8	10
최대속도 Max. speed(wpm)	40	60	80
버킷용량 Bucket volume(L)	1.5(Sliding bucket)		
제품피딩방식 Feeding methodv	진동, 벨트, 스크류 Vibration, Belt, Screw		
계량범위 Weighing range(g)	15 ~ 1000		
계량정밀도 Accuracy(±g)	1 ~ 2		
모니터 Monitor	10.4 inch color touch screen		
소요 전력 Power consumption	220V 1PH 50/60Hz		
재질 Material in contact product	Stainless steel(SUS304)		
작동온도 Operation temperture(°C)	0 ~ 40		
방진방수등급 IP protection class	IP66		
선택사양 Option	제품에 특성에 따라 적용할 수 있는 다양한 선택사양이 있습니다. Various Options are available. Please contact EZ Systems.		

- 계량속도는 제품의 모양, 비중 및 목표중량에 따라 변동될 수 있습니다.
- 계량정밀도는 목표중량, 계량속도 및 주변환경에 따라 변동될 수 있습니다.
- 상기 사양은 기계 개선을 위해 예고 없이 변동될 수 있습니다.

- Depends on product shape, product density, target weight, etc.
- Depends on target weight, weighing speed and conditions.
- The technical modifications are reserved.

## 적용 Applications

HMR 제품 / 정육제품 / 해산물 등

Sticky and fresh product / Fresh meat / Vegetables / Sea foods



# Supporting Products

---



**Rotary Fill-Seal Machine**



**Vertical Form-Fill-Seal Machine**



**Liquid Filler**



**Vibrofeeder & Hopper**



**Bucket Elevator**



**Bucket Lifter**





**Z Shaped Belt Conveyor**



**Turn Table**



**Metal Detector**



**Check Weigher**



**Semi-Auto Taping Machine**



**Flexible Conveyor**



**(주)이지시스템**

인천광역시 서구 장고개로  
243번길 19

Tel. 032-584-3330

Fax. 032-584-3329

**EZ SYSTEMS CO.,LTD**

19, Janggogae-ro 243beon-gil,  
Seo-gu,Incheon,Korea

Tel. +82 032-584-3330

Fax. +82 032-584-3329

[www.ezsystem21.com](http://www.ezsystem21.com)